

HD43 STRAIGHT CRIMP/CRIMP PLUG 8GTIS

43-012-D6-BG

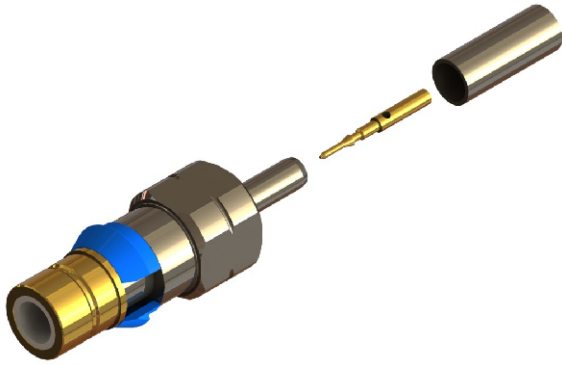

images for illustration purposes only

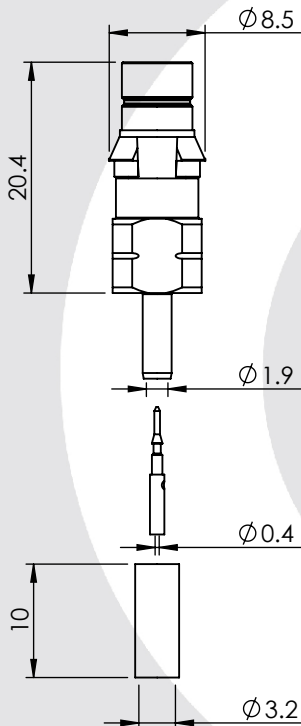

Suitable for Cables:

(BG) RA8000

Stripping Dimensions

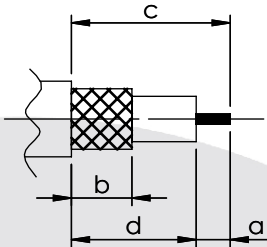

- a = 4.5 mm
- b = 8.0 mm
- c = 21.0 mm
- d = 16.5 mm

* CUT FOIL TO DIM. "b"

Assembly Procedure: AP023

Tooling

- Centre Contact: Square Crimp Tool No: HTS-43
- Crimp Sleeve: HEX 3.25mm A/F Tool No: HTS-43
- Alignment Tool: Not Applicable Extraction: 96-832-TOOL

Environmental Specification

Operating Temp: -40 T0 +100 Deg C
IP Rating (Mated): NONE

Electrical Specification

Impedance: 75 Ohm
Frequency: 0-3 GHz
Dielectric W/V: 1500 Veff
Insulation res: 5000 M-Ohm

Mechanical Specification

Contact Retention: 22 N min
Cable Retention: 60 N min
Mating cycles: 250
Weight: 5.63 g

Connector Interface

image for illustration purposes only

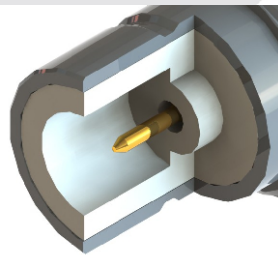

5	RETAINING RING	PBT	N/A
4	CRIMP SLEEVE	BRASS	NICKEL
3	INSULATOR	PTFE	N/A
2	CENTRE CONTACT	PHOSPHOR BRONZE	GOLD
1	BODY	BRASS	NICKEL/GOLD
ITEM	DESCRIPTION	MATERIAL	PLATING

A4	SHEET 1 OF 1	DIMENSIONS ARE IN MILLIMETRES				
REVISION :	A04		NAME	SIGNATURE	DATE	
DRAWN	GE				06/05/2005	
ISSUE :	2		CHK'D	PS		06/05/2007
			APPV'D			
<p>6-8 COLNE ROAD, TWICKENHAM, MIDDLESEX. TW1 4JR</p> <p>THE INFORMATION IS GIVEN AS AN INDICATION ONLY AND IS SUBJECT TO CHANGE WITHOUT NOTICE. IN THE CONTINUAL GOAL TO IMPROVE OUR PRODUCTS, WE RESERVE THE RIGHT TO MAKE ANY MODIFICATIONS NECESSARY WITHOUT PRIOR NOTICE.</p>						